

Designed by Paavo Tynell

### PRODUCT

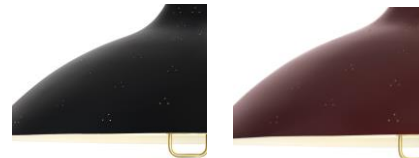

### COLOURS



// Soft Black

// Chianti Red



// Classic White

// Brass



// Bistro Green

### DESCRIPTION

The 1965 Pendant was originally designed by Paavo Tynell in 1948. Like many of his best-known designs, the pendant was designed for the Finland House in New York - one of the most ambitious and successful projects of all time to showcase Finnish design. Perfecting the techniques of metal finishes, Tynell developed the 1965 Pendant with his exceptional ability to capture and translate a grace and exuberant lightness into his brass creations. Characterized by its triangular perforation pattern, an artistic detail utilised by Tynell in several of his lighting objects, the 1965 Pendant reflects the distinguished craftsmanship of the Finnish designer. With a frosted glass diffuser that softens the light, the pendant contributes to a subtle and tranquil environment.

### VERSION - 1965 Pendant

Canopy and small parts // Polished Brass.

Fabric wire // Brass.

Wire // Steel.

Diffuser // Transparent glass, frosted on one side.

Shade variations // Brass, Black, White, Red, or Green.

- Brass / White inside // Polished Brass / RAL 9002 // Shiny / Gloss level 10-15
- Soft Black / White inside // RAL 9011 / RAL 9002 // Gloss level 15-20 / Gloss level 10-15
- Classic White / White inside // RAL 9002 / RAL 9002 // Gloss level 15-20 / Gloss level 10-15
- Chianti Red / White inside // RAL 3004 / RAL 9002 // Gloss level 15-20 / Gloss level 10-15
- Bistro Green / White inside // RAL 6012 / RAL 9002 // Gloss level 15-20 / Gloss level 10-15

Due to natural materials surface and structure can vary.

### MEASUREMENTS

Order item - look for part number in the pricelist.

Series contains the following:

- A1965 Pendant**
- 5321 Table Lamp**
- 9464 Wall Lamp**
- 9602 Floor Lamp**

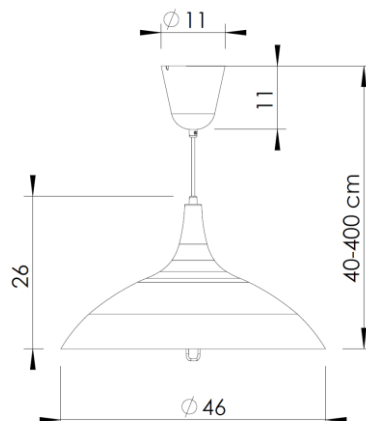

### FACTS

#### MEASUREMENT LAMP- L X W X H MM

Height: 26 cm

Shade: Ø46 cm

Cord - exposed out of lamp: App. 380 cm

#### WEIGHT ITEM - LAMP INCL. WIRE

3,3 kg

#### PACKAGING TYPE

Cardboard box

#### PACKAGING MEASUREMENT - L X W X H CM

L:53 X W:53 X H:35 cm

#### WEIGHT PACKAGING TOTAL

1,8 kg

#### WEIGHT LAMP + PACKAGING - TOTAL

5,1 kg

#### NUMBER OF PARCELS

1 pcs.

## ACCESSORIES

-

## ENVIRONMENT

-

## TESTS

-

## CERTIFICATION AND LABELS

CE-certified

## SAFETY INSTRUCTIONS

If the cord or other electrical part is damaged, switch of the lamp and do not use it until it is repaired by a qualified electrician.

## INSTALLATION INSTRUCTIONS

Instructions document no.: 64-20-002-XX

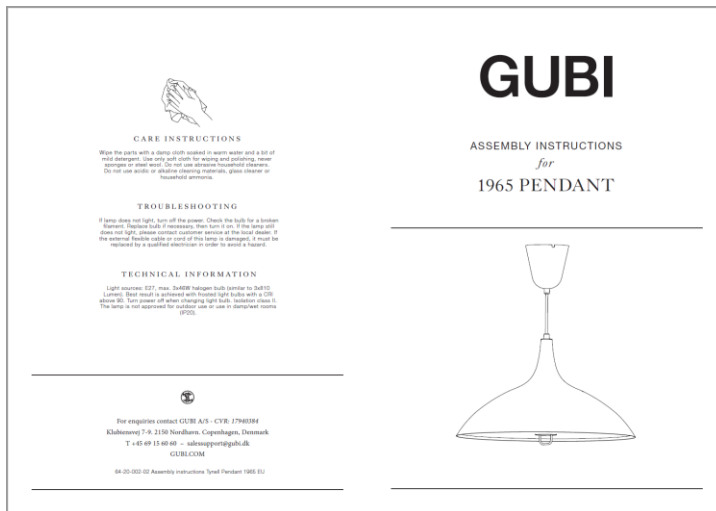

## LIGHT SOURCE:

- Socket: 3xE27 base
- Bulb types recommended:



- Recommended light sources:

If LED is chosen, only dimmable versions work.

810 Lumen (~ 60W incandescent  
 ~ 40-60W halogen - 6-10W LED)

- Max. light out put for above lamps:

810 Lumen (~ 60W incandescent ~ 40-60W halogen)  
 By LED 1530 Lumen (~ 13-16W)

- Best result is achieved with frosted light bulbs  
 with a CRI (Colour Rendering Index) larger than 90.

- Lightbulb not included.

- All lamps can be fitted with a dimmer - Please contact your local electrician.

- If dimming wanted use dimmable light bulbs only.

- Can be connected to a dimming system if proper receivers are installed  
 in front of the lamp.

\*Euro voltage: 230 V

\*Frequency: 50 Hz

\*Supply voltage: AC power ~

\*Normally Closed: IP20



Class II / Double insulated



CE-Mark



Luminaires accepted for mounting on a flammable base

